

## TECHNICAL SPECIFICATIONS

	PARAMETERS	MEASUREMENTS
<b>BODY DIMENSIONS</b>	LENGTH	2020mm
	WIDTH	785mm
	HEIGHT	1103mm
	WHEEL BASE	1285mm
	GROUND CLEARANCE	160mm
	KERB WEIGHT	Disc 118kg, Drum 117kg
	SEAT LENGTH	705mm
	SEAT HEIGHT	790mm
	FUEL TANK CAPACITY	11L
<b>ENGINE</b>	TYPE	4 Stroke, SI Engine
	DISPLACEMENT	124cc
	MAX NET POWER	8kW @ 7500 rpm
	MAX NET TORQUE	10.9 N-m @ 6000 rpm
	FUEL SYSTEM	PGM-FI
	BORE x STROKE	50.0 X 63.1mm
	COMPRESSION RATIO	10.0:1
	STARTING METHOD	Self/Kick
<b>TRANSMISSION</b>	CLUTCH TYPE	Multiplate Wet Clutch
	NO. OF GEARS	5 Gears
<b>TYRES &amp; BRAKES</b>	TYRE SIZE & TYPE (FRONT)	80/100-18 M/C 47P, Tubeless
	TYRE SIZE & TYPE (REAR)	80/100-18 M/C 54P, Tubeless
	BRAKE SIZE & TYPE (FRONT)	Disc 240mm, Drum 130mm
	BRAKE SIZE & TYPE (REAR)	Drum 130mm
<b>FRAME &amp; SUSPENSION</b>	FRAME TYPE	Diamond Type
	FRONT SUSPENSION	Telescopic
	REAR SUSPENSION	Hydraulic Type
<b>ELECTRICALS</b>	BATTERY	12V, 5.0Ah
	HEAD LAMP	LED, DC

• +The technical specifications and design of the vehicle may vary according to the requirements and conditions without any notice • \*Distance-to-empty, real time and average mileage readings may vary as per variant and riding conditions • SP 125 meets Bharat Stage VI norms • Product shown in the picture may vary from actual product available in the market • Accessories shown in the picture are not part of standard equipment • ^Mileage has increased by 16% for SP 125 as compared to BS IV to BS VI • \*\*Conditions apply ^^Only rear tyre is HET.

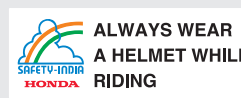

**Other Honda Shield Products\*\***  
Annual Maintenance Contract  
Road Side Assistance  
Engine Health Assurance

Follow us on



Dealer Stamp:

MATTE AXIS GREY METALLIC



PEARL SIREN BLUE



STRIKING GREEN



IMPERIAL RED METALLIC



**HONDA**  
The Power of Dreams

सब कर देंगे सपने



**SP125**  
**STRICTLY FOR THE ADVANCED**

Honda is **HONDA**

Honda Motorcycle and Scooter India Pvt. Ltd.  
Registered Office: Commercial Complex II, Sector - 49-50, Golf Course Extension Road, Gurugram - 122018 (Haryana)  
Visit us at: [www.honda2wheelersindia.com](http://www.honda2wheelersindia.com) Customer Care: [customercare@honda2wheelersindia.com](mailto:customercare@honda2wheelersindia.com)





**SP125**

**IT'S TIME TO BE ADVANCED**

Experience thrilling performance and advanced technology come together in the SP 125. It comes with Honda's globally acclaimed Enhanced Smart Power (eSP) technology with an eco-friendly, BS-VI engine in a dynamic personality that makes for an equally smart and stylish ride. So, get ready to make a serious, attitude-packed style statement with a bike that's strictly for the advanced.

**A QUIET REVOLUTION**



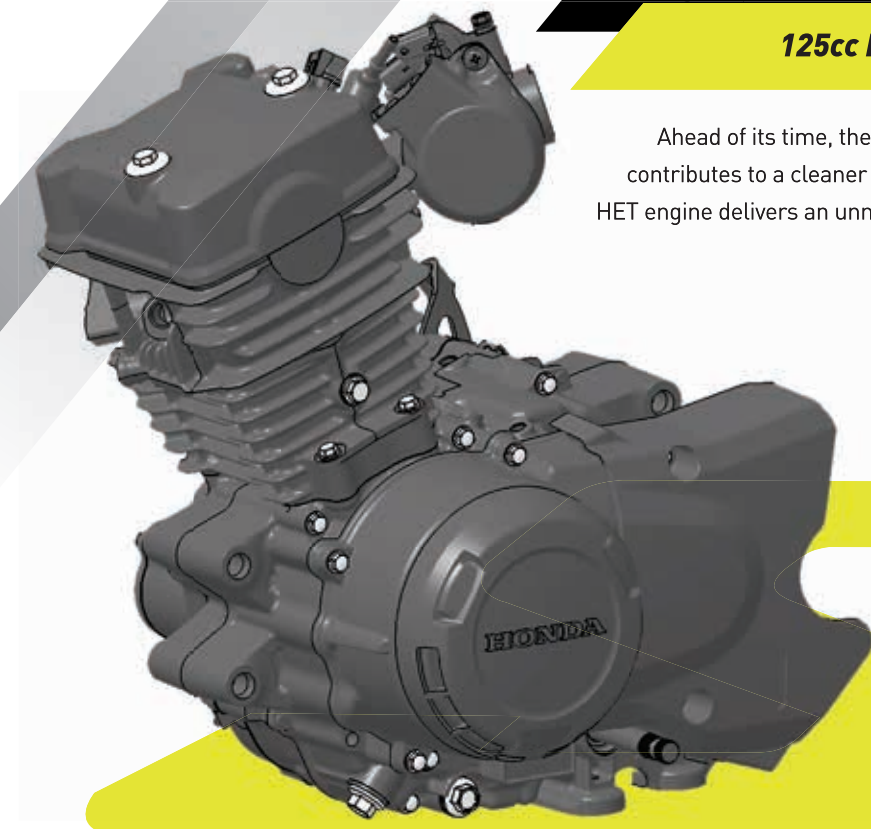

**125cc HET BS VI ENGINE**

Ahead of its time, the latest innovation in engine contributes to a cleaner environment. The intelligent HET engine delivers an unmatched performance.



**eSP**

With SP 125, expect nothing but the best. Honda's Enhanced Smart Power (eSP) technology maximizes performance and fuel-efficiency by reducing friction. The ACG starter integrated with eSP technology starts the engine quietly giving you the best of riding experience and technology.

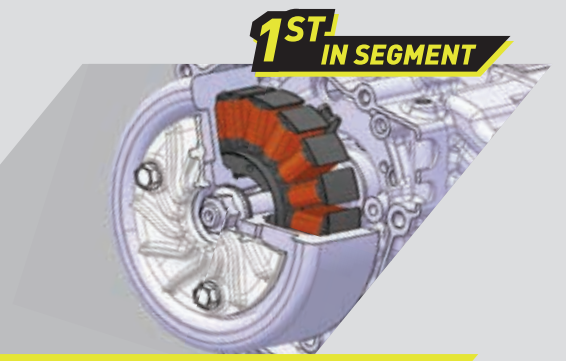

**SILENT START WITH ACG**

Honda's unique ACG starter motor removes gear meshing noise and helps start the engine without a jolt.



**PGM-FI**

PGM-FI system with 8 sensors constantly injects optimum fuel and air mixture resulting in efficient combustion that aids in consistent power output and higher mileage.



**FRICION REDUCTION**

The piston cooling jet reduces friction and maintains optimum engine temperature. The offset crank, rocker roller arm fitted with needle bearing further reduces the frictional losses in the engine.

# ADVANCED TECHNOLOGY



**[16%  
MORE  
MILEAGE]**

**MILEAGE UP**

A completely new engine powered by Honda's globally acclaimed eSP Technology delivers 16%^ higher mileage.



**FULL DIGITAL METER**

Always stay up-to-date with the Full Digital Meter which displays Real-time Fuel-efficiency, Average Fuel efficiency, Distance-to-empty, Service Due Indicator, Gear Position Indicator & Eco Indicator.



**HET TUBELESS TYRE^^**

Honda's low-rolling resistance tubeless tyre is specially designed to increase fuel-efficiency.

**ADVANCED  
TECHNOLOGY**





**AGGRESSIVE TANK DESIGN WITH EDGY GRAPHICS**

A definite head-turner, the muscular fuel tank design with edgy graphics makes it very appealing.



**MODERN HEADLAMP DESIGN**

A sure shot style statement, the sharp headlamp with its excellent illumination creates a lasting first impression.



**SPORTY SPLIT ALLOY WHEELS**

A split second is all you'll need to make your presence felt with the distinctive 5-spoke Split Alloy Wheels.



**BOLD REAR STANCE WITH TAIL LAMP**

The bold rear seamlessly integrates the tail lamp with the body enhancing the design statement.



**PREMIUM CHROME MUFFLER COVER**

Stylish Chrome Muffler enhances the sporty looks.

**ADVANCED  
STYLE**



# ADVANCED COMFORT & CONVENIENCE



**1<sup>ST</sup> IN SEGMENT**



**SHARP LED DC HEADLAMP**

The Sharp LED DC Headlamp gives consistent illumination while riding irrespective of the speed and riding conditions.

**1<sup>ST</sup> IN SEGMENT**



**ENGINE START/STOP SWITCH**

Start and stop your bike with just the flick of a switch anytime, anywhere. Enjoy enhanced convenience.

**1<sup>ST</sup> IN SEGMENT**



**INTEGRATED HEADLAMP BEAM & PASSING SWITCH**

Integrated Smart Single Switch for passing signal and low/high beam.

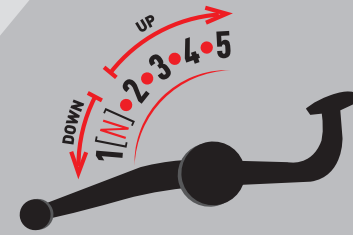

**5-SPEED TRANSMISSION**

Enhance the smooth yet thrilling ride experience with 5-Speed transmission.



**5-STEP ADJUSTABLE REAR SUSPENSION**

Makes your ride comfortable with 5 Step Adjustable Rear Suspension on all road conditions.



**1<sup>ST</sup> IN SEGMENT**

**3 + 3 YEARS WARRANTY PACKAGE**

Complete peace of mind with 6 years warranty package, comprising of 3 years standard and 3 years optional service warranty.

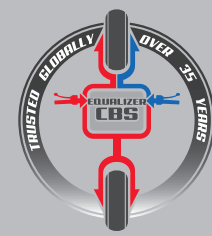

**CBS WITH EQUALIZER**

The Combi-Brake System with Equalizer reduces braking distance, so you can ride with confidence.



**SEAL CHAIN**

The Seal Chain is low on maintenance and high on durability for a hassle-free riding experience.